

# Sapphire<sup>®</sup>

## Service & Commissioning Manual Internal / External Models

### Fully Modulating Low NOx Boiler for Domestic Liquid Fuel Heating



**Sapphire 6-32kW**

Sapphire fully modulating liquid fuel boiler, operates via OpenTherm protocol for smart connectivity, Intelligent flame detection functionality. ErP and BED tested and approved. UK ecodesign of energy consuming regulations 2024.



# Contents Page

<b>1</b>	<b>Declaration</b>	<b>1</b>
<b>2</b>	<b>Information &amp; General Warnings</b>	
2.0	Introduction	2
2.1	Symbols used in the manual	2
2.2	Delivery of the appliance and the User Manual	2
2.3	Guarantee and responsibility	2
2.4	Liquid fuel information and general instructions	4
2.5	Product disclaimer statement	4
<b>3</b>	<b>Safety and Prevention</b>	
3.0	Introduction	5
3.1	Health and Safety information	5
<b>4</b>	<b>Appliance Introduction</b>	
4.0	Appliance panel descriptions	6
4.1	Checking the characteristics of the appliance	6
<b>5</b>	<b>Electrical</b>	
5.0	Wiring diagram	7
<b>6</b>	<b>Sapphire Modulating Blue Flame Burner</b>	
6.0	Technical description of the burner	8
6.1	Burner components	8
6.2	Commissioning pre-checks	9
6.3	Check list	9
<b>7</b>	<b>Boiler Operation and Commissioning</b>	
7.0	Connecting the service & commissioning touch-screen interface	10
7.1	Initial boiler start up, bleeding the fuel pump and commissioning	10
7.2	Setting up the boiler set-point temperature	13
7.3	Upon completion of commissioning/service	13
<b>8</b>	<b>Maintenance / Service</b>	
8.0	Maintenance & service	14
8.1	Maintenance programme	14
8.2	Checking & cleaning	14
8.3	Replacing the nozzle	14
8.4	Servicing of the Boiler Plate Sealing Gasket, Blast tube, Electrode, Air Bush and Flame Detector Sight Glass	14
8.5	Electrode/Head Settings (Air Bush)	15
8.6	Boiler Service	18
8.7	Condensate Pump/Trap	19
<b>9</b>	<b>Fault Codes</b>	
10.0	Boiler lockouts and fault codes	20

# Declaration

## 1.0 Declaration

Sapphire 

**EOGB**   
Reliable energy. Flexible approach.



**UK  
CA**

**UK  
NI**



### **EC DECLARATION OF CONFORMITY** in accordance with **BS EN ISO/IEC 17050-1:2004**

We: EOGB Energy Products Ltd

Of: 5 Howard Road,  
Eaton Socon,  
St Neots,  
Cambs,  
PE19 8ET

Telephone: +44 (0)1480 477066  
Email: sales@sapphireboilers.co.uk  
Website: www.sapphireboilers.co.uk

Declare that;  
Equipment: Sapphire Domestic Modulating Liquid Fuel Boiler  
Model: **Sapphire 6-32 kW**

In accordance with the following Directives and Normative documents:

2006/95/EEC Conforms with the safety objectives of the Low Voltage Directive and its amending directives.  
2004/108/EC Conforms with the essential protection requirements of the Electromagnetic Compatibility Directive and its amending directives.  
92/42/EC Conforms with the requirements of the Boiler Efficiency Directive.  
2010/30/EU Conforms with the Labelling of Energy related products to EU (no) 811/2013  
2009/125/EC Conforms with the Ecodesign of Energy related products to EU (no) 813/2013

I hereby declare that the equipment named above has been designed to comply with the relevant sections of the above standard and meets all essential requirements of the specified Directives.

Signed: Martin Cooke

Signature

Position: Managing Director

Date

1st October 2021

# Information and General Warnings

## 2.0 Introduction

---

The Sapphire Customer User Manual supplied with the appliance:

- is an integral and essential part of the product and must not be separated from the appliance. It must therefore be kept carefully for any necessary consultation and must accompany the appliance even if it is transferred to another owner or user, or to another system. If the manual is lost or damaged, another copy can be requested from EOGB on request.
- is designed for use by qualified personnel.
- offers important indications and instructions relating to the installation safety, start-up, use and maintenance of the boiler.

## 2.1 Symbols used in the manual

---

In some parts of the manual you will see triangular DANGER signs. Pay great attention to these, as they indicate a situation of potential danger.

The dangers can be of 4 levels, as indicated below.



This symbol indicates operations which, if not carried out correctly, cause serious injury, death or long-term health risks.



This symbol indicates operations which, if not carried out correctly, may cause serious injury, death or long-term health risks.



This symbol indicates operations which, if not carried out correctly, may cause damage to the machine and/or injury to people.



This symbol indicates operations which, if not carried out correctly, lead to electric shocks with lethal consequences.

## 2.2 Delivery of the appliance and the User Manual

---

The recommendation is to keep the User Manual in the room where the appliance is to be installed.

- The appliance installer, must carefully inform the user about the use of the system;
- Any further tests that may be required before activating the complete installation;
- Maintenance, and the need to have the appliance and system checked at least once a year by an Approved Sapphire Agent.

To ensure a periodic check, the manufacturer recommends entering into a Maintenance Contract.

## 2.3 Guarantee and responsibility

---

Thank you for purchasing the EOGB Energy Products Ltd fully modulating liquid fuel Sapphire condensing appliance.

EOGB Energy products Ltd guarantees the manufacture of the boiler including all electrical and mechanical components for a period of twelve months from the date of installation, provided that the boiler has been installed in full accordance with the installation and servicing instructions issued. This will be extended to a total period of 5 years for non-serviceable parts and 25 years for the heat exchanger if the appliance is registered with EOGB Energy Products Ltd within thirty days of installation and it is serviced at twelve month intervals. **See main Terms and Conditions below.**

### Registering the product with EOGB Energy Products Ltd

Please register your fully modulating liquid fuel Sapphire condensing appliance with EOGB Energy Products Ltd within thirty days of installation. To do so visit: **[www.sapphireboilers.co.uk](http://www.sapphireboilers.co.uk)**

If your appliance should fail within the guarantee period, you must contact the Sapphire Agent who installed/commissioned the appliance who will arrange for the repair under the terms of the guarantee, providing that the appliance has been correctly installed, commissioned and serviced (if the appliance has been installed for more than twelve months) by a competent person and the fault is not due to tampering, running out of liquid fuel, liquid fuel contamination, debris, system water contamination, misuse, trapped air or the failure of any external components not supplied by EOGB Energy Products Ltd, e.g. fire valve, motorised valve, etc.



# Information and General Warnings

## In the first instance

Contact the Sapphire Agent who installed and commissioned the appliance to ensure that the fault does not lie with the system components or any incorrect setting of the system controls that falls outside of the manufacturer's guarantee otherwise a service charge could result. EOGB Energy Products Ltd will not be liable for any charges arising from this process.

## If a fault covered by the manufacturer's guarantee is found

Ask your Sapphire Agent to contact EOGB Energy Products Ltd Service Department on +44 (0)1480 477066 who will arrange for a competent service engineer to rectify the fault.

## Remember - before you contact EOGB Energy Products Ltd

- Ensure the appliance has been installed, commissioned and serviced by a Sapphire Approved Agent and in accordance with the installation and servicing instructions.
- Ensure there is liquid fuel to supply the burner.
- Ensure the problem is not being caused by the heating system or its controls. Consult the appliance handbook for guidance.

## Free of charge repairs

During the guarantee period no charge for parts or labour will be made provided that the appliance has been installed and commissioned correctly in accordance with the manufacturer's installation and servicing instructions, it was registered with EOGB Energy Products Ltd within thirty days of installation and for appliances over twelve months old, full details and reports of annual service is available on request.

The following documents must be made available to EOGB Energy Products Ltd Limited on request:

- Proof of purchase
- CD10 Installation Completion Form (or equivalent document)
- CD11 Commissioning Report Form (or equivalent document)
- Service documents (CD11 or equivalent document)

## Chargeable repairs

A charge may be made (if necessary following testing of parts) if the breakdown is due to any fault(s) caused by the plumbing or heating system, e.g. contamination of parts due to system contamination, sludge, scale, debris or trapped air. Refer to 'Extent of manufacturer's guarantee'.

## Extent of manufacturer's guarantee

The manufacturer's guarantee does NOT cover the following:

- If the appliance has not been installed, commissioned, by a Sapphire Approved Agent in accordance with the installation and servicing instructions.
- Instances where the serial number has been removed or made illegible.
- Fault(s) due to accidental damage, tampering, unauthorised adjustment, neglect, misuse or operating the application contrary to the manufacturer's installation and servicing instructions.
- Damage due to external causes such as bad weather conditions (flood, storms, lightning, frost, snow, or ice), fire, explosion, accident or theft.
- Fault(s) due to incorrectly sized expansion vessel(s), incorrect vessel charge pressure or inadequate expansion on the system.
- Fault(s) caused by external electrics and external components not supplied by EOGB Energy Products Ltd
- Problems caused by lack of liquid fuel or faults with the fuel storage and supply system.
- Fault(s) due to contamination of the liquid fuel storage and supply system, e.g. water or debris.
- Bleeding or removing liquid fuel storage tank contamination or blockages from liquid fuel lines.
- Problems due to the flue system being incorrectly fitted or not installed to meet installation requirements.
- Application servicing, de-scaling or flushing.
- Cleaning out condensate traps/discharge pipes or thawing out frozen condensate pipework.
- Checking and replenishing system pressure.
- Liquid fuel supply pipelines, electrical cables and plugs, external controls not supplied by EOGB Energy Products Ltd.
- Heating system components, such as radiators, pipes, fittings, pumps and valves not supplied by EOGB Energy Products Ltd.
- Instances where the appliance has been un-installed and reinstalled in another location.
- Use of spare parts not authorised by EOGB Energy Products Ltd
- Consumable items including, but not limited to, liquid fuel nozzles, liquid fuel hoses, gaskets and seals.

## IMPORTANT

The nozzle supplied on the burner are only covered for the period up to the time of the first service (twelve months), and must be changed on the first service and on every annual service thereafter.

## IMPORTANT

A suitable liquid fuel filter with a minimum 15µ filtration must be installed in the liquid fuel supply line.

Do not wait until the fuel supply runs out before you re-order. Sludge in the bottom of the tank may be drawn into the fuel lines.

It is recommended that the appliance is switched off when the new liquid fuel supply is delivered and that the fuel is allowed to settle for an hour before restarting the appliance.

## Terms of manufacturer's guarantee

- The Company shall mean EOGB Energy Products Ltd.
- The appliance must be installed by a Sapphire approved agent and in full accordance with the relevant Codes of Practice, Regulations and Legislation in force at the time of installation.
- The appliance is guaranteed for 5 years on non-serviceable parts and 25 years on the heat exchanger from the date of installation, providing that every twelve months the annual service has been completed and the appliance registered with the Company within thirty days of installation. Any work undertaken must be authorised by the Company and carried out by a Sapphire approved service engineer.

# Information and General Warnings

- This guarantee will be invalid if the appliance does not have an annual (every twelve month) service and will then be limited to twelve months from the date of installation.
- The shell (heat exchanger) of the appliance is covered by a 25 year parts and labour guarantee from the date of installation. This is subject to the following:
  - The appliance is operated correctly, in accordance with the Installation and servicing instructions.
  - EOGB Energy products Ltd strongly recommends that a in-line magnetic filter/s is fitted in the heating system pipework. This should be installed and regularly serviced in accordance with the filter manufacturer's instructions. We reserve the right to ask for proof of installation – failure to provide this may result in the guarantee becoming invalid.
  - Proof is provided that the system has been flushed or chemically cleaned where appropriate (refer to BS 7593) and that the required quantity of a suitable corrosion inhibitor added.
  - Proof of annual servicing (including the checking of any expansion vessels and pressure relief valves) must be provided if and when requested by the Company.
  - This guarantee does not cover breakdowns caused by incorrect installation, neglect, misuse, accident or failure to operate the appliance in accordance with the manufacturer's installation and servicing instructions.
  - The appliance is registered with the Company within thirty days of installation. Failure to do so does not affect your statutory rights.
  - The balance of the guarantee is transferable providing the installation is serviced prior to the dwelling's new owners taking up residence. EOGB Energy Products Ltd must be informed of the new owner's details.
  - The Company will endeavour to provide prompt service in the unlikely event of a problem occurring, but cannot be held responsible for any consequences of delay however caused.
- This guarantee applies to EOGB Energy Products Ltd appliances purchased and installed on the UK mainland, Isle of Wight, Channel Islands, Isle of Man and Scottish Isles only. Provision of in-guarantee cover elsewhere in the UK is subject to agreement with the Company.
- All claims under this guarantee must be made to the Company prior to any work being undertaken. Invoices for call out/repair work by any third party will not be accepted unless previously authorised by the Company.
- Proof of purchase and date of installation, commissioning and service documents must be provided on request.
- If a replacement appliance is supplied under the guarantee (due to a manufacturing fault) the product guarantee continues from the installation date of the original boiler and not from the installation date of the replacement.
- The appliance must be connected to a mains water supply (installations utilising a private water supply are not covered by this guarantee).
- Breakdown/failure due to lime scale will not be covered by this guarantee.
- The replacement of an application under this guarantee does not include any consequential costs, such as the removal or replacement of worktops, kitchen units, etc.
- The appliance (excluding external modules) must not be sited in a location where it may be subjected to frost.

## 2.4 Liquid fuel information and general instructions

---

To ensure consistency, the supplier of the fuel must be able to demonstrate that the fuel supplied is in conformity with the liquid fuel standard stated in this manual and compliance with a recognised Quality Control and management system to ensure high standards are maintained within the storage, blending and delivery processes.

The installation of a liquid fuel storage tank and its ancillaries must also be prepared BEFORE liquid fuel is introduced.. Checks and preparation should include:

- For new installations, make sure that all materials and seals in the liquid fuel storage and supply line to the burner are compatible with the liquid fuel as stated in this manual. For all installations, there must be a good quality liquid fuel compatible liquid fuel strainer type filter at the tank with a micron rating of no more than 50 microns and then a secondary liquid fuel compatible paper type filter with a micron rating of 15 or less at the appliance end to protect the burner from contamination.
- If an existing liquid fuel storage tank is to be used then in addition to the materials checks as detailed above, it will be essential that the tank is first inspected for condition and checked for water or other contamination. EOGB strongly recommends that the existing tanks and their contents are cleaned via fuel polishing/conditioning and filters replaced prior to utilisation with the new appliance.
- EOGB recommends that the in line and burner fuel pump filters are inspected and if required replaced at least every 12 months during burner use, before the burner start-up following a long period of discontinue operation and even more frequently where contamination has occurred. Particular attention is needed when inspecting and checking for fuel leakages from seals, gaskets and hoses.

## 2.5 Product disclaimer statement

---

CAREFULLY READ THE FOLLOWING DISCLAIMER. YOU ACCEPT AND AGREE TO BE BOUND BY THIS DISCLAIMER BY PURCHASING EOGB BOILERS/ BURNERS AND/OR COMPONENTS.

Although the information and recommendations (hereinafter "Information") in this guidance is presented in good faith, believed to be correct and has been carefully checked, EOGB (and its subsidiaries) makes no representations or warranties as to the completeness or accuracy of the Information. Information is supplied upon the condition that the persons receiving will make their own determination as to its suitability for their purposes prior to use. In no event will EOGB (and its subsidiaries) be responsible for damages of any nature whatsoever resulting from the use of or reliance upon Information.

Other than set forth herein, EOGB (and its subsidiaries) makes no additional warranties with respect to the boiler/burner, either express or implied, including that of merchantability or fitness for a particular purpose or use.

In no event shall EOGB (and its subsidiaries) be liable for any indirect, incidental, special or consequential damages including, without limitation, loss of profits, damages for loss of business profits, business interruption, loss of business information, loss of equipment, or other pecuniary loss or compensation for services whether or not it is advised of the possibility of such damages.

With the exception of injuries to persons, EOGB's liability is limited to the customer's right to return defective/non-conforming products as provided by the relevant product warranty.

# Safety and Prevention

## 3.0 Introduction

The boiler has been designed and built in compliance with current regulations and directives, applying the known technical rules of safety and envisaging potential danger situations. It is necessary, however, to bear in mind that the improper use of the equipment may lead to situations which could result in risk of the user or third parties, as well as to the health, safety and well-being of the boiler, burner or other items. Inattention, thoughtlessness and excessive confidence often cause accidents.

Please remember the following:

- The burner must only ever be used as expressly described. Any other use should be considered improper and therefore dangerous.  
In particular:
- It can be applied to boilers expressly named by the manufacturer, the type and pressure of the fuel, the voltage and frequency of the electrical power supply, the minimum and maximum ratings for which the burner has been regulated, the pressurisation of the combustion chamber, the dimensions of the combustion chamber and the room temperature must all be within the values indicated in the instruction manual.
- Modification of the burner to alter its performance and destinations is not permitted under any circumstances.
- The burner must be used in technically safe working conditions. Any disturbances that could compromise safety must be quickly eliminated.
- Opening or tampering with the burner components is not permitted, apart from the parts requiring maintenance.
- Only those parts detailed as available as spare parts by the manufacturer can be replaced.
- Only liquid fuel as specified specifically for this make and model of appliance can be utilised.

## 3.1 Health and safety information

The installer should be aware of their responsibilities under the current, local Health and Safety at Work Act. The interest of safety is best served if the boiler is installed by a competent, qualified engineer, OFTEC trained and registered. If not, a Building Notice is required in England & Wales. Other parts of the British Isles, including the Channel Islands, also require notification to building control.



**Please note that the installation, commissioning and servicing MUST only be carried out by a competent, qualified engineer, trained and registered to generic industry standards of competence and who has undertaken additional EOGB manufacturers appliance and burner specific training. In accordance with BS5410 part 1 2019.**

Adhesives, sealants and paints used in the manufacture of the product are cured and present no known hazards when used in the manner for which they are intended. The following other materials are present in the product:

### INSULATION MATERIALS

**Material Types:** Ceramic fibre board, mineral wool

**Description:** Rigid board, slabs, sleeves, gaskets, ropes.

**Known Hazards:** May cause temporary irritation or rash to skin. High dust levels may irritate eyes and upper respiratory system.

**Precautions:** Avoid unnecessary or rough handling, or harsh abrasion of boards. Normal handling and use of material should not produce high dust levels. Avoid inhalation, and contact with skin and eyes. After handling always follow normal good hygiene practices.

**Protection:** Use disposable glove, face mask and eye protection.

**First Aid:** Eyes - If irritation occurs, wash eyes with copious amounts of water. If symptoms persist, seek immediate medical advice.

Skin- If irritation occurs, wash under running water before washing with soap and water.

Inhalation - Remove to fresh air, drink water to clear throat and blow nose to remove dust/fibres.

Ingestion - Drink plenty of water.

### SEALANT AND ADHESIVE

**Material Types:** Silicone elastomer.

**Description:** Sealant and adhesive.

**Known Hazards:** Irritation to eyes.

**Precautions:** Avoid inhalation of vapour, contact with eyes and prolonged or repeated contact with skin. After handling always follow normal good hygiene practices.

**Protection:** Use eye protection. Rubber or plastic gloves should be worn where repeated contact occurs and a face mask worn when working in confined spaces.

**First Aid:** Eyes - Flush eyes with water for 15 minutes. Seek immediate medical attention.

Skin - Wipe off and wash with soap and water.

Inhalation - Remove to fresh air.

### LIQUID FUELS

**Known Hazards:** - The effect of mineral oils on the skin vary according to the duration of exposure and the type of liquid fuel. The lighter fractions remove the protective grease naturally present on the skin, leaving it dry, liable to crack and more prone to damage by cuts, abrasions and irritant chemicals.

Skin rashes (Oil acne) most often on arms, but also on any part of the body in contact with oil or oily clothing.

Contact with fuel oils can cause dermatitis.

#### Precautions:

Avoid as far as possible any skin contact with mineral oil or with clothing contaminated with mineral oil. The use of a lanolin-based barrier cream is recommended, in conjunction with regular washing with soap and rinsing with water to ensure all oil is removed from the skin.

Take care to prevent clothing, especially underwear, from becoming contaminated with oil.

Do not put oily rags or tools in pockets, especially trouser pockets.

Have first-aid treatment at once for an injury, however slight.

Do not inhale any vapours from mineral oils.

**For further information on all materials used on the Sapphire Boiler, please see the Material Safety Data Sheets (MSDS) section on our website [www.sapphireboilers.co.uk](http://www.sapphireboilers.co.uk)**

# Appliance Introduction

## 4.0 Appliance panel descriptions

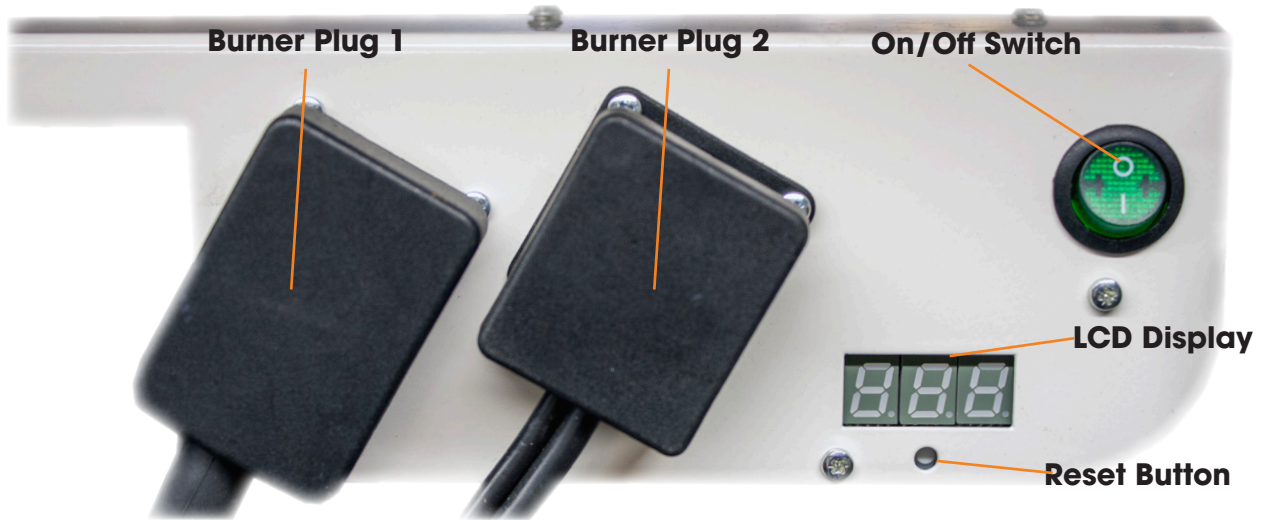

Fig. 1

## 4.1 Checking the characteristics of the appliance

CE UK UK CA NI Sapphire

Sapphire Modulating Condensing  
Liquid Fuel Appliance

**Serial NO:**

**Date of Manufacture:** 00/00/0000

**Model NO :** Sapphire 00/00

**Min Kw rated Output:** Kw

**Max Kw rated Output:** Kw

**Nozzle:** See Manual

**Max Operating System Pressure:** Bar

**Max Operating Temperature:** °C

**Fuel Type:**

**Seasonal Space Heating Eff:** %

**ErP Class:**

**230V ~ 50Hz (3 AMP)**

This Appliance MUST be commissioned by an Sapphire Approved Agent prior to use. Failure to do so may invalidate the Warranty.

**EOGB** Reliable energy. Flexible approach.

EOGB Energy Products Ltd  
5, Howard Road, Eaton Socon  
Saint Neots, Cambs, PE19 8ET  
T 01480 477066  
E sales@sapphireboilers.co.uk  
W sapphireboilers.co.uk

WARRENTY VOID IF LABEL REMOVED

Fig. 2

# Electrical

## 5.0 Wiring diagram

Before June 2025

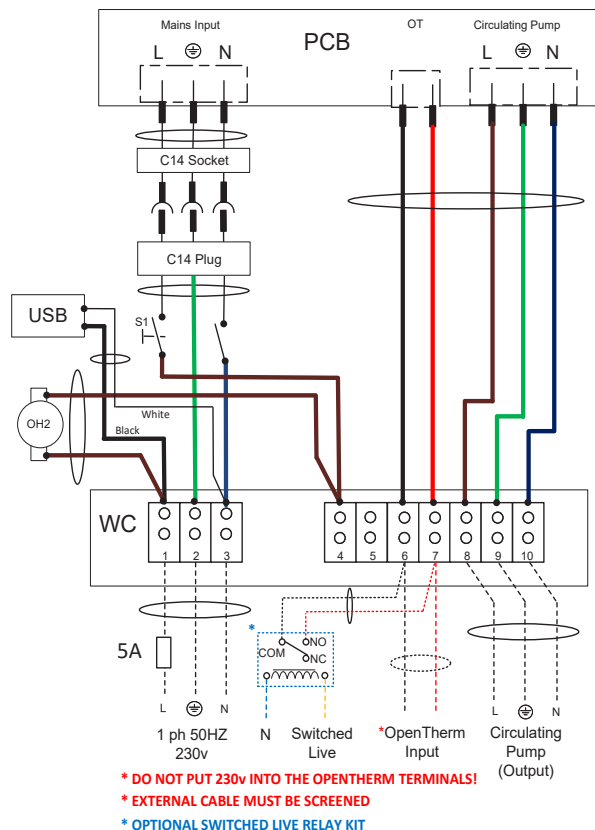

After June 2025

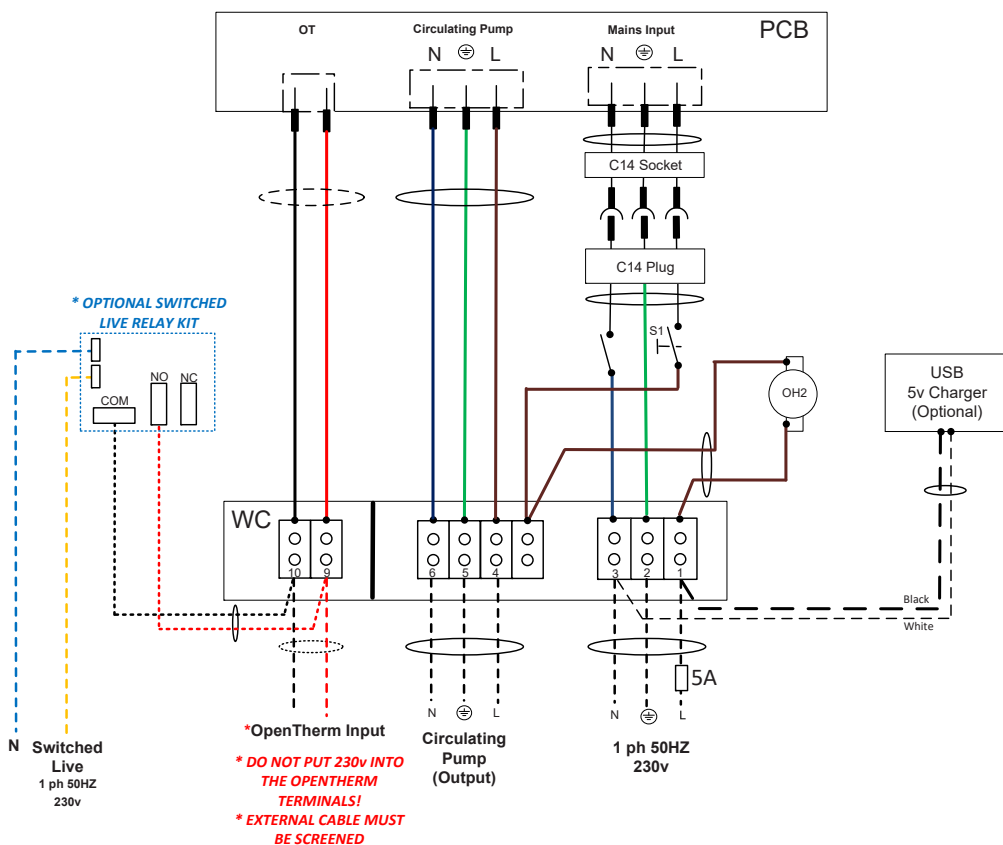

Fig. 3

# Sapphire Modulating Blue Flame Burner

## 6.0 Technical description of the burner

Fully modulating low NOx burner for domestic heating

EOGB's Sapphire blue flame burner delivers excellence in performance and reliability, backed by first-class technical expertise and a personable, responsive service.

Low NOx - High performance

Sapphire has been designed from the outset to bring about a step-change improvement in domestic heating performance. The blue flame burner not only meets the 2018 ErP Directive NOx emission standard, at the same time the Sapphire's fully modulating operation when combined with OpenTherm type controls delivers the best in energy efficiency and carbon emission reduction of any domestic liquid fuel on burner the market today.

Sapphire's precision load tracking and optimum efficiency across the firing range delivers industry-leading energy performance for ultra-low running costs and significantly reduced carbon emissions, which when combined with lower carbon liquid fuels will enable our sector to achieve virtually carbon neutral home heating for years to come.

## 6.1 Burner components

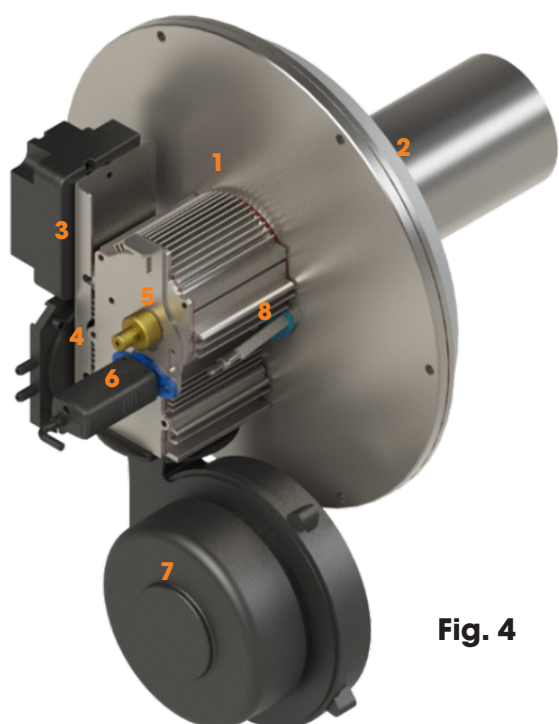

Fig. 4



Fig. 5



Fig. 6

Labelled Number	Description
1	Burner Mounting Plate
2	Blast Tube
3	EBI Ignition Transformer
4	Air Pressure Switch
5	Inner Oil Pipe / Head Adjustment
6	KLC Flame Scanner (24V)
7	Inverter Driven Fan
8	Electrodes
9	Burner Mounting Plate Gasket
10	Nozzle
11	Flame Scanner Site Glass
12	Oil Pump
13	Transducer
14	Solenoid Coil
15	Pump Motor

# Sapphire Modulating Blue Flame Burner

## 6.2 Commissioning pre-checks

---

**Prior to commissioning, please ensure the boiler has been installed in accordance of the requirements set out in BS5410 Part 1 (Domestic) or Part 2 (Non-Domestic) and any local/ regional building regulations.**

**Before first firing of the boiler, please ensure that the commissioning is being undertaken by a competent or OFTEC qualified engineer who has undertaken the relevant EOGB Modulating Burner Training.**

**Failure to ensure that the commissioning is not being carried out by an approved Sapphire Service Agent will invalidate the warranty.**



## 6.3 Check list

---

Ensure the boiler has been installed as per the EOGB Sapphire Boiler Installation Manual

Ensure that all flow and return connections are free from leaks, valves are open, and that the boiler is filled with water.

Check and establish if the liquid fuel in the tank is suitable for this boiler specification.

Check that there are filters fitted with the correct filtration requirements See EOGB Sapphire Boiler Installation Manual.

Ensure the oil supply is correctly connected and deaerator is used.

Ensure that all oil valves are open between the tank and boiler and check for any leaks. Important: ensure there are NO oil isolation valves on the return side!

Ensure that flues are correctly sited, fitted and sealed.

Check all electrical connections and ensure the burner is Earthed

Check that the boilers condensate pipe is fitted correctly and securely and has been filled with water

Switch on the boiler and follow the "Initial Burner Start up & Commissioning Procedure" in Section 7.1.

# Boiler Operation and Commissioning

## 7.0 Connecting the service & commissioning touchscreen interface

When commissioning or servicing the boiler, the Touchscreen Interface (TSI) MUST be connected in order to make boiler/ burner adjustments. This TSI CAN ONLY be acquired and used by a Sapphire Approved Agent.

To connect the TSI, you must first disconnect the LCD Display on the boilers front panel. (FIG 7). Once disconnected, simply plug in the TSI

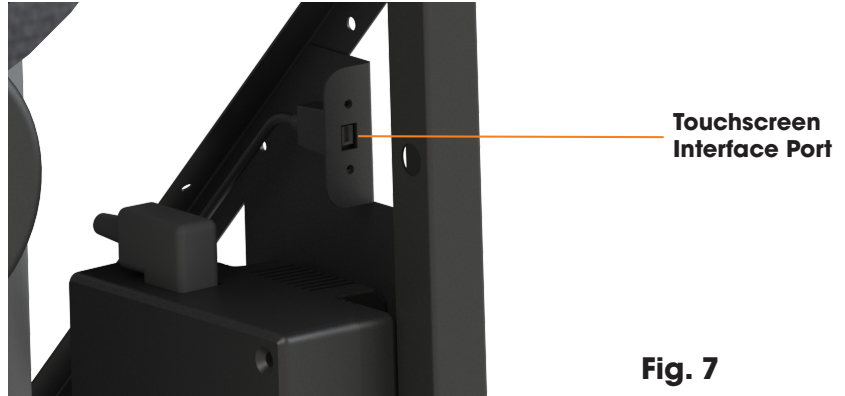

Fig. 7

## 7.1 Initial boiler start up, bleeding the fuel pump and commissioning



**Any attempt to fire or commission this appliance by unauthorized persons will invalidate the appliance warranty.**

**Step 1** - Switch on any isolation switches and turn on the on/off power switch on the boiler front panel. Fig. 8



Fig. 8

Upon initial start up the "System Loading Screen" will appear for several seconds whilst the burner initiates the start up program. Fig. 9

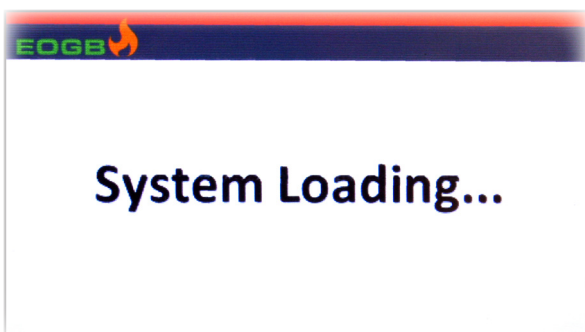

Fig. 9

**Step 2** - Upon successful loading, the "Temperature Display Screen" will be displayed. Fig. 10 Press the "EOGB Logo" in the top left hand corner to open the "System Ramp Test Screen".



Fig. 10

**Step 3** - On the "System Ramp Test Screen" Fig. 11, press the "Next" button in the bottom right hand corner to move through the different setting windows until you reach the "Run Time System Control Screen" Fig. 11 - 18

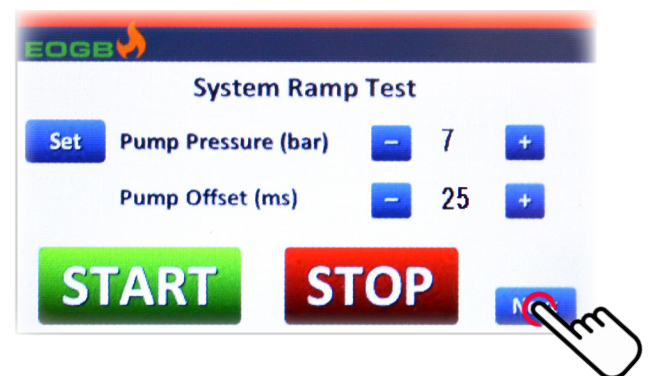

Fig. 11



Fig. 12



Fig. 18

**Step 5** - Once you reach the "Run Time System Control Screen" press the "Start" button **Fig. 19**



Fig. 13

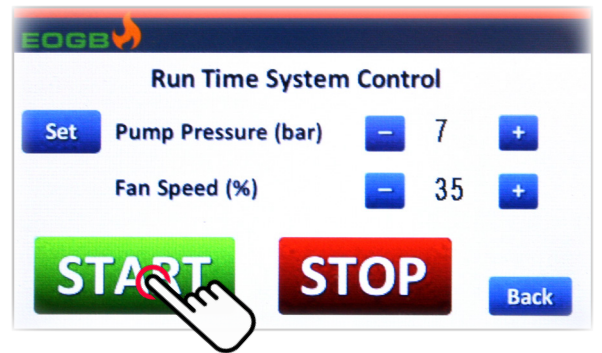

Fig. 19

The burner will begin its start sequence and will attempt to establish a flame on "Pump Pressure (bar)" Setting 7 Bar\*

At this point open the pressure gauge manifold port to bleed any air from the fuel pump. If the burner does not successfully establish pump pressure then close the pressure gauge manifold to stop air from venting back into the oil supply. Then try again to bleed the air from the pump by resetting the burner (Press "Start") and repeat the procedure above.

**DO NOT Repeat this more than 3 times as the pump may be running dry.**  
**Please note that the fuel pump is not designed to vent all the air from the pipework/fuel supply tank.**  
**It is advised to use a priming pump to prime the fuel through to the pump/de-aerator first.**



Fig. 14



Fig. 15

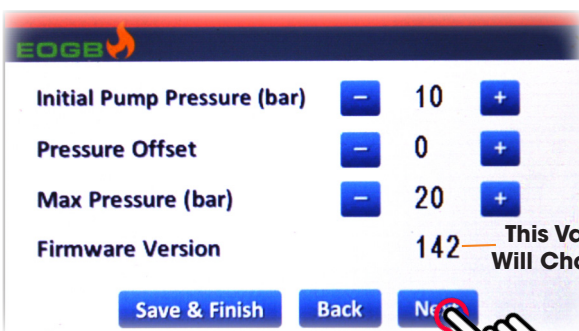

Fig. 16

# Boiler Operation and Commissioning

**Step 6** - Once the air has been bled from the fuel pump the burner should have established a flame on "Pump Pressure (bar) Setting 7 Bar"

\*Please note the start pressure setting may differ as it can be altered in the parameter screens under "Initial Pump Pressure (bar)".

If the burner has not successfully established a flame on the Initial Pump Pressure setting then alter the "Fan Speed %" by pressing either + or - buttons and retry. **Fig. 20**



**Fig. 20**

**Step 7** - Now the boiler is firing, locate the combustion analyser test points and carry out a smoke and combustion test with the aid of a smoke pump and combustion flue gas analyser to ensure the combustion levels are suitable. **Fig. 21**

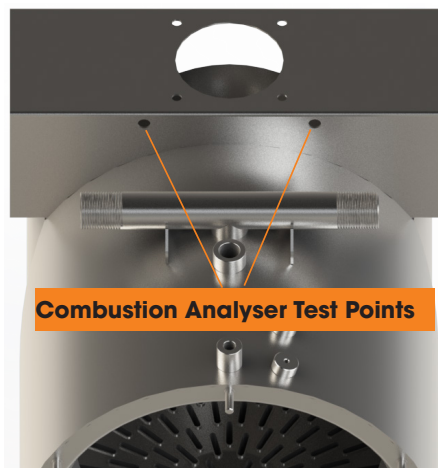

**Fig. 21**

Once acceptable combustion settings have been achieved, It is **VERY IMPORTANT** to Press the "Set" button to **SAVE** the setting. **Fig. 22**



**Fig. 22**

Then press the + or - buttons to increase/decrease the pump pressure setting (min 5bar to max 20bar depending on boiler model). Then set/trim the fan speed so that flue gas analyser reads the correct CO2% value given as 12.5-13.5%. **Fig. 23**

**Repeat the process for each "Pump Pressure (bar)" setting**



**Fig. 23**

Once acceptable combustion settings have been achieved, It is **VERY IMPORTANT** to Press the "Set" button to **SAVE** the setting each time a combustion point is set. **Fig. 24**



**Fig. 24**

After all modulating pump pressure points have been adjusted and saved by pressing the "Set" button. Press the "Back" button. **Fig. 25**



**Fig. 25**

# Boiler Operation and Commissioning

This will take you back to the "Parameters setting pages" From here press the "Save & Finish" button to exit the Service and Commission procedure. **Fig. 26**

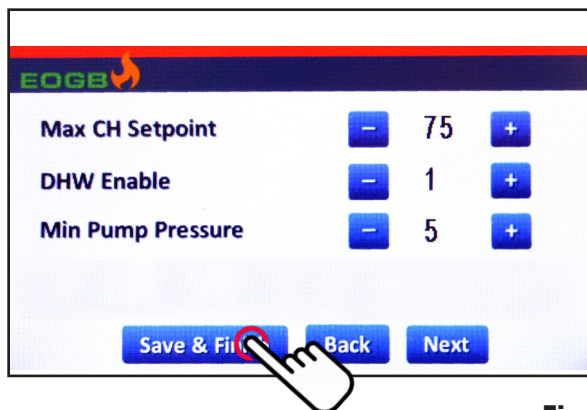

**Fig. 26**

The burner will then reset. Once the burner has been successfully commissioned the screen will display the water temperature and a flame symbol to show that the burner is in operation. **Fig. 27**

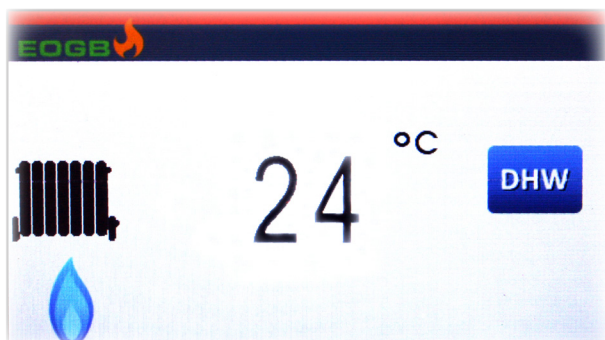

**Fig. 27**

## 7.2 Setting the Boiler Setpoint Temperature

To set the boiler setpoint temperature. Press the "EOGB Logo" in the top left hand corner to open the "System Ramp Test Screen" **Fig. 28**

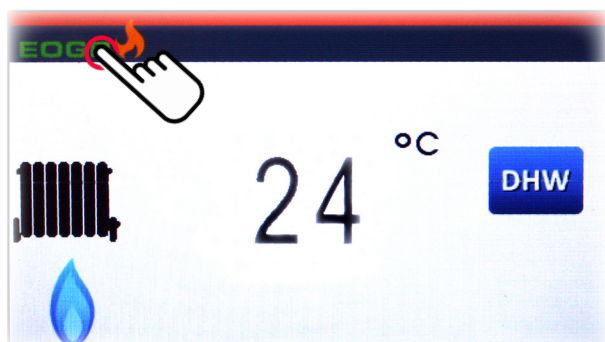

**Fig. 28**

On the "System Ramp Test Screen", press the "Next" button in the bottom right hand corner to move through the different setting windows until you reach the "Max CH Setpoint Option" **Fig. 29**

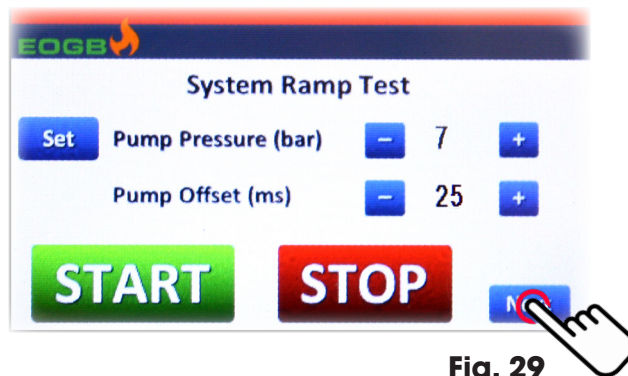

**Fig. 29**

To alter the temperature setpoint simply press the + or - buttons to adjust "Max CH Setpoint" **Fig. 30**

Please note that EOGB pre-set and highly recommend this setting to be left at 70 °C to ensure correct flow and return temperatures for the system design.



**Fig. 30**

Once the "Max CH Setpoint" set, press the "Save & Finish" Button. **Fig. 31**

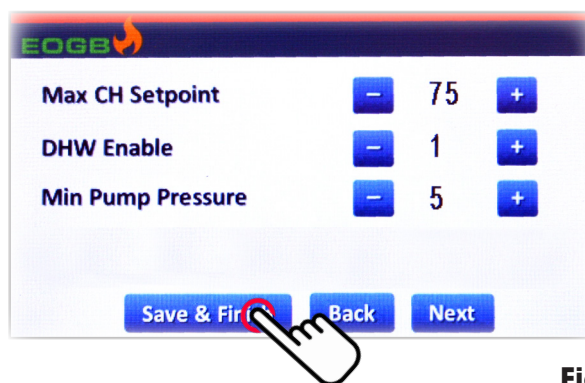

**Fig. 31**

## 7.3 Upon completion of commissioning/service

Ensure that the TSI is removed and the LCD display is plugged back in. The LCD screen will then show the boiler temperature.

Note, if the boiler was to lockout for any reason, this LCD screen will indicate a fault code. Please see Fault Finding on page 28 for further information.

Please ensure that all necessary paperwork has been completed and includes the commissioning and service logs at the back of the user manual.

# Maintenance / Service

## 8.0 Maintenance & service

---

### Notes on safety for the maintenance

Periodic maintenance is essential for the good operation, safety, yield and duration of the burner. It allows you to reduce consumption and polluting emissions and to keep the product in a reliable state over time.



The maintenance interventions and the calibration of the burner must only be carried out by a Sapphire Approved Agent, in accordance with the contents of this manual and in compliance with the standards and regulations of current laws.

Before carrying out any maintenance, cleaning or checking operations:



Disconnect the electricity supply to the boiler;



Isolate the fuel supply.

## 8.1 Maintenance programme

---

The combustion system should be checked at least **once a year** by a Sapphire Approved Agent.

## 8.2 Checking & cleaning

---

### Combustion head

Open the burner and make sure that all components of the combustion head are in good condition, not deformed by the high temperatures, free of impurities from the surroundings and correctly positioned.

Clean the combustion head in the fuel exit area, on the diffuser disc.

### Burner

Check for excess wear or loose screws and clean the burner.

### Fan

Visual check to ensure fan is undamaged/clean.

### Flame Detector

Clean the flame detector bulb and site glass

### Electrodes

Check the correct position of electrodes

### Nozzles

It is advisable to replace nozzles every year

**Do not attempt to clean the nozzle**

### Filters

Check the filter elements in-line and at the nozzle. Clean or replace if necessary. If rust or other impurities are observed inside the pump, use a separate pump to lift any water and other impurities that may have deposited on the bottom of the storage tank.

### Pump

Please check that the supply line and filters are clear. The use of a pump vacuum gauge will assist in this. This measure permits the cause of the anomaly to be traced to either the suction line or the pump.

If the problem lies in the suction line, check to make sure that the filter is clean and that air is not entering the piping.

### Boiler/Heat Exchanger

Clean the boiler/heat exchanger as per **section 8.6** in order to keep all the original combustion characteristics intact, especially the flue gas temperature and combustion chamber pressure.

### High Pressure Oil Delivery Hose (between the fuel pump and nozzle line)

Check the condition of the high pressure oil delivery hose periodically. It will have to be replaced at least every **5 years**.



The high pressure oil delivery hose supplied with this burner is suitable for use with Kerosene and HVO.

### Fuel tank

If water or contamination is present within the fuel tank, it is essential that this is removed before the equipment is to be used. If in doubt about how to achieve this then please contact the fuel or oil tank supplier.

### Combustion

In case the combustion values found at the beginning of the intervention do not respect the standards in force or in any case, do not correspond to a proper combustion, contact the Technical Support and allow them to carry out the necessary adjustments.

Allow the burner to work for 10 minutes and then check the combustion readings with the parameters indicated within this manual.

Then carry out a combustion check verifying:

- Flue gas temperature;
- Content of CO<sub>2</sub> (%); 13-13.5%
- Content of CO (ppm);  
May start high but will decrease once running.
- Smoke value according to Bacharach scale.

### Condensate Pump (if fitted)

Ensure the condensate pump and pipework are not leaking and the condensate pump is pumping away the contents satisfactory.

# Maintenance / Service

## 8.3 Replacing the nozzle

As part of a burner service, the oil nozzle must be replaced. To access the nozzle simply loosen the nozzle holding plate fastening screws. **Fig. 32**

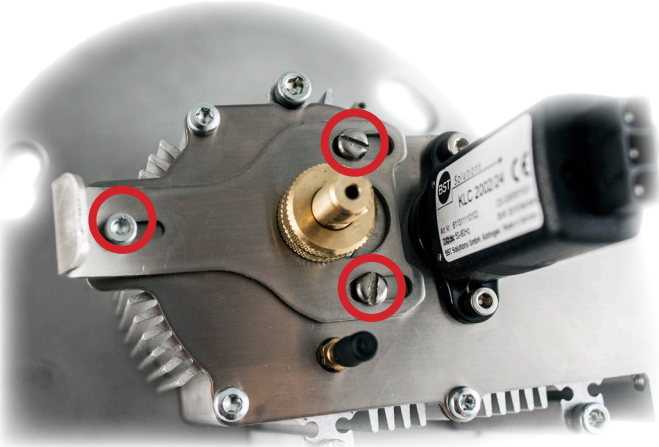

**Fig. 32**

With the nozzle holding plate screws loose, slide the nozzle holding plate up. **Fig. 33**

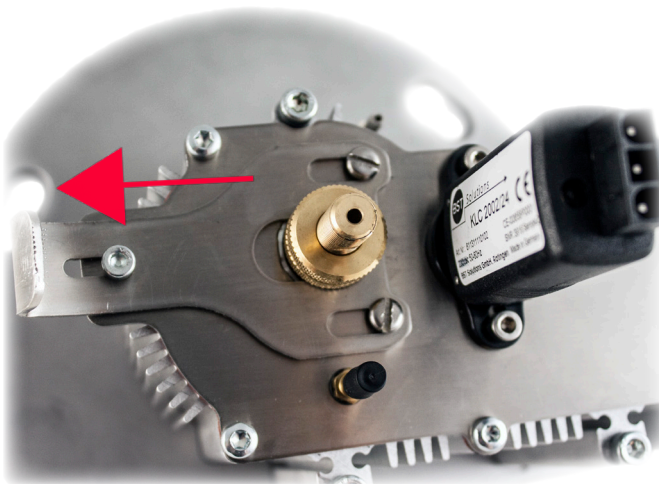

**Fig. 33**

With the nozzle holding plate slid up, simply pull out the Nozzle pipe assembly. **Fig. 34**

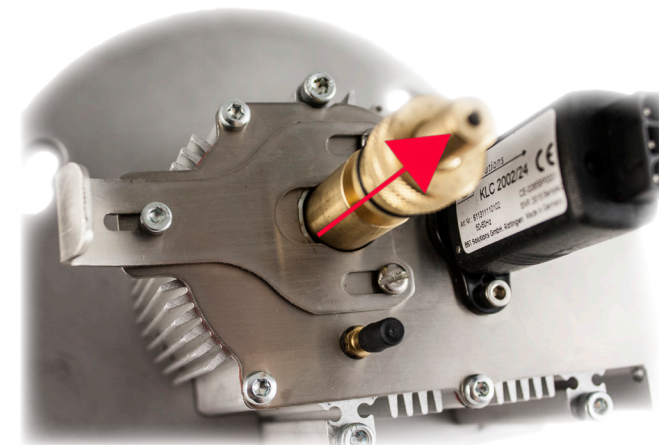

**Fig. 34**

With the oil pipe assembly removed, the nozzle can then be changed. **Fig. 35**

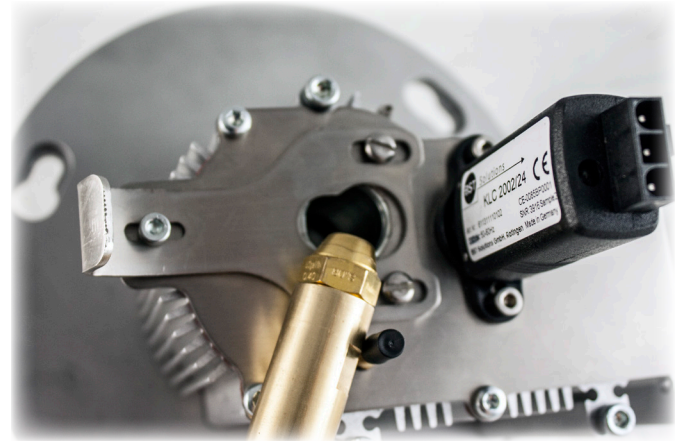

**Fig. 35**

Use the handy nozzle removal tool built into the left hand side of the boiler casing for ease.



**Fig. 36**



**Fig. 37**

Once the nozzle has been changed, simply reverse the procedure to refit the inner oil pipe assembly back onto the burner.

# Maintenance / Service

## 8.4 Servicing of the boiler plate sealing gasket, blast tube, electrodes, air bush and flame detector sight glass



**IMPORTANT - Ensure the boilers electrics have been isolated safely before carrying out any service works**  
 Before removing the burner for service, please ensure the nozzle pipe assembly has been removed (see section 8.3)

To remove the burner, Unplug the two burner power plugs from the boiler panel. **Fig. 38, 39**

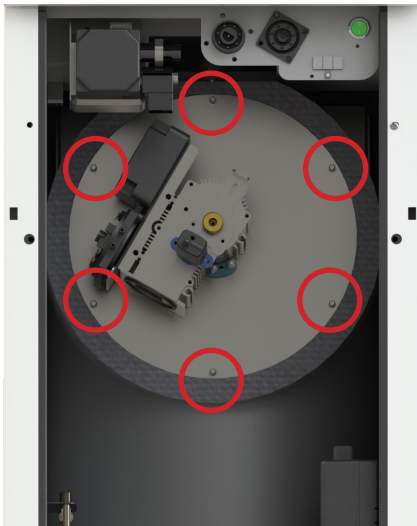

**Fig. 38**



**Fig. 39**

Remove the burner from the boiler by loosening the six mounting nuts on the burner mounting plate. **Fig. 40**



**Fig. 40**

Whilst removing the burner from the boiler, remove the air intake hose from the air intake adaptor. **Fig. 41**



**Fig. 41**

Once removed, the Boiler Plate Sealing Gasket can be checked for damage and replaced if necessary. **Fig. 42**



**Fig. 42**

**IMPORTANT - Ensure the Burner Boiler Plate Sealing Gasket is not obstructing the Low NOx blast tube recirculating slots at the base of the blast tube Fig. 43**



**Fig. 43**

The blast tube can also be inspected/cleaned. To remove, unscrew the 4 x M4 cap heads, twist blast tube anti-clockwise and pull away. (The previous version of blast tube was supplied in 2 parts & undone by pushing in the end and twisting to release) **Fig. 44**

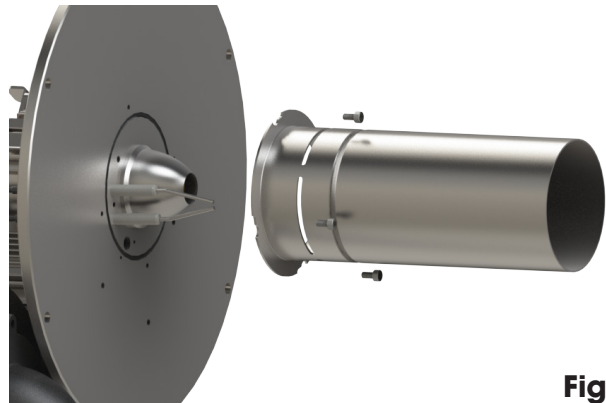

**Fig. 44**

Once removed, the electrodes and head settings can be cleaned and checked. **Fig. 45**

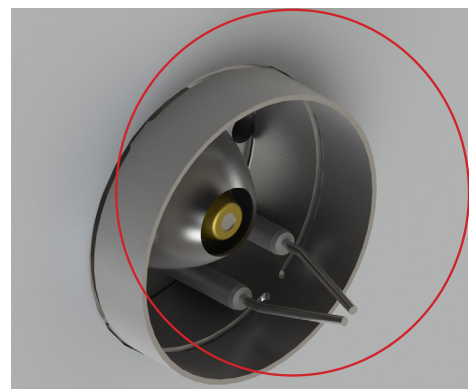

**Fig. 45**

# Maintenance / Service

To change or inspect the ignition electrodes, loosen and remove the fixing bolt and slide each electrode out. **Fig. 46**



**Fig. 46**

To access and clean the sight glass, loosen and remove the fastening bolts to remove the plate. The sight glass and gasket can then be inspected/cleaned. **Fig. 49**

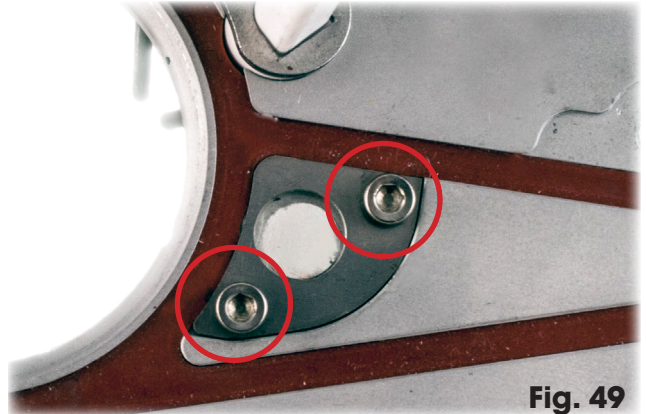

**Fig. 49**

As part of the service, the Flame Detector Sight Glass and Air Bush must be checked and cleaned. The Sight Glass and Air Bush can be accessed by removing the burner fan house assembly from the mounting plate. To gain access, loosen and remove the fixing bolts. **Fig. 47**

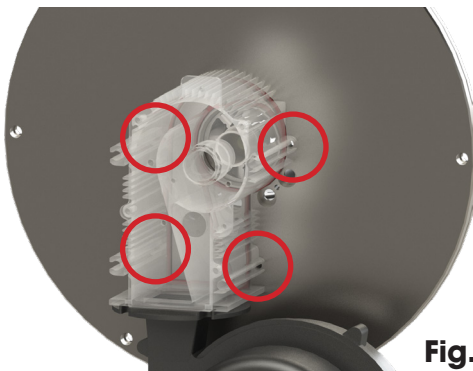

**Fig. 47**

With the burner fan-house removed, we now have access to the sight glass, electrodes and brake plate. **Fig. 48**

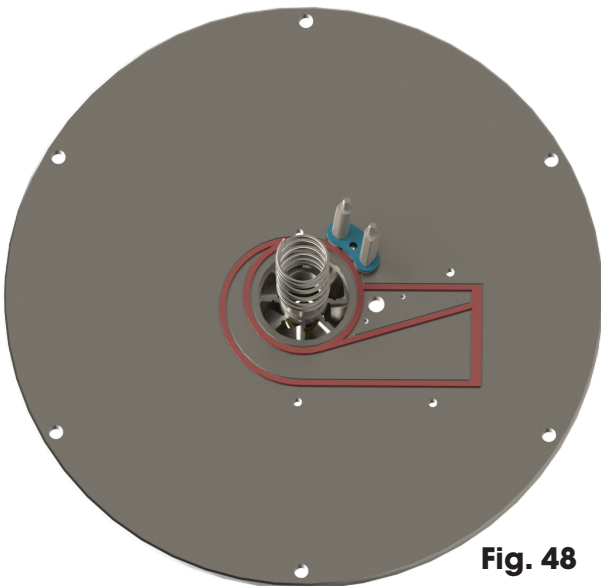

**Fig. 48**

To access and inspect the Air Bush, simply lift out the brake plate / spring. Check that the diffuser fins within the brake plate are clean. **Fig. 50**



**Fig. 50**

# Maintenance / Service

## 8.5 Electrode/head settings (air bush)



The position of the electrodes can be critical to ensure the ignition spark is generated in the correct place. To ensure a safe reliable ignition of the fuel, please check your electrode settings using the diagrams below

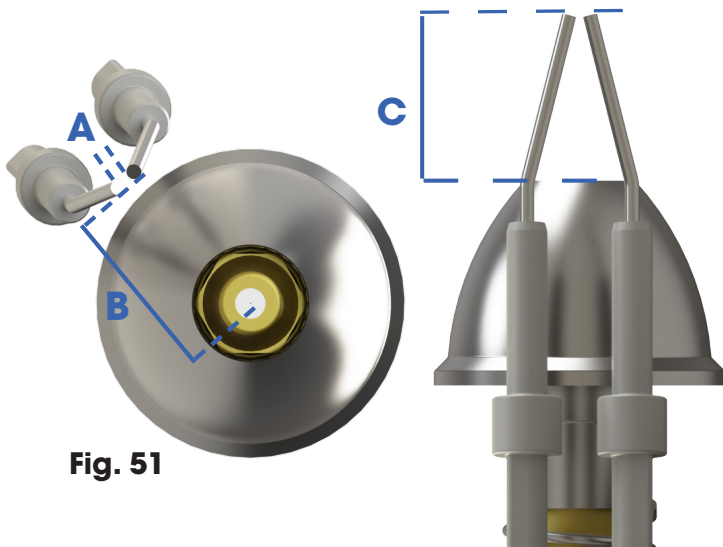

Fig. 51

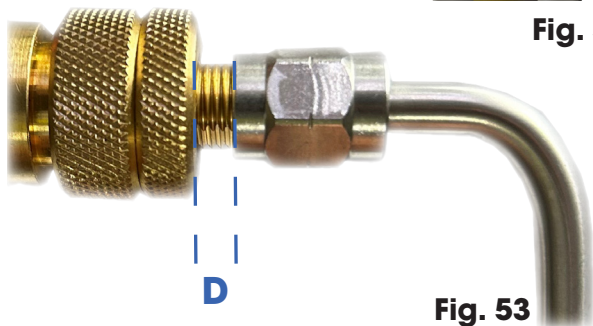

Fig. 53

A (mm)	B (mm)	C (mm)	D * (Threads Showing)
3-4	23-25	33-35	3-4

Fig. 54

\* Site condition dependant!

The nozzle assembly (D) can be adjusted by increasing/decreasing the brass adjustment nut.

Loosen the fixing nut first, then use the adjustment nut to move the nozzle assembly forwards or backwards until the correct head setting is achieved. Fig. 55

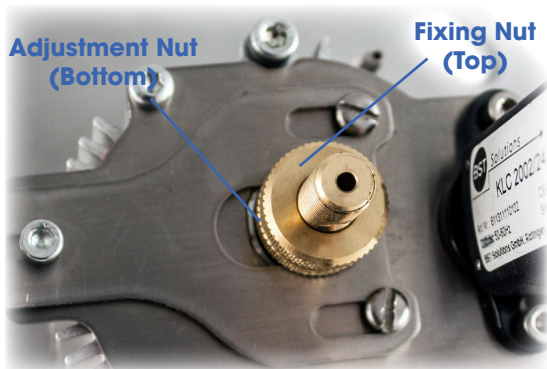

Fig. 55

## 8.6 Boiler service

Once the burner has been removed, the combustion chamber / heat exchanger can then be inspected / cleaned. Fig. 56



Fig. 56

Ensure that any loose deposits found in the combustion chamber/heat exchanger are removed by a soft brush or vacuum cleaner.

Using a suitable heat exchanger brush, pass the brush head down each passage way ensuring that each one is clear, please note that any debris should end up at the bottom of the heat exchanger.

**IMPORTANT! If another type of heat exchanger brush is used, it must NOT contain any metal brush filaments that could cause damage to the stainless steel exchanger. Any damaged caused by the use of the incorrect brush will invalidate the boilers warranty!**



EOGB recommends that a cleaning solution such as SCALEBREAKER LS3 from KAMCO or other spray on liquid boiler cleaner compound be used. (see cleaning product instructions for how to use)

Once the cleaning solution has been applied. Simply remove the condensate trap located at the bottom of the heat exchanger and pass through warm water from the top. A waste water collection tray located under the condensate outlet will capture the waste water. Fig 57

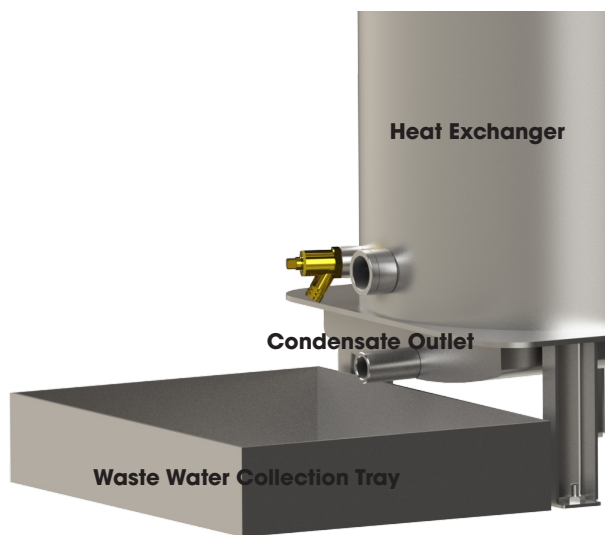

Fig. 57

# Maintenance / Service

## 8.7 Condensate pump/trap (if fitted)

During the service the condensate trap and pump must be checked before cleaned.

To check/clean the trap, disconnect the push on flexible grey waste discharge hose from the trap. Check and clean this hose if required.



Caution, the waste discharge hose may contain some condensate.

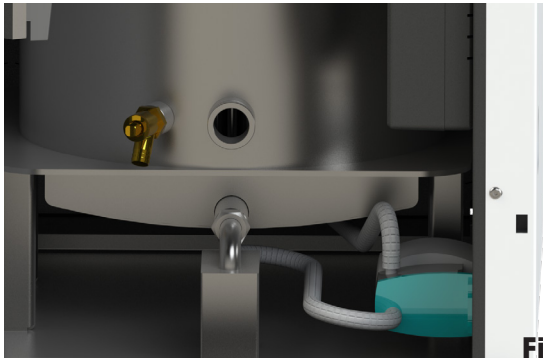

**Fig. 58**

Then remove the trap itself by loosening the union fitting at the rear. Then clean out the trap with warm water.



**When refitting the trap ensure the trap union PTFE washer is fitted before filling with water!**

When checking/cleaning the condensate pump, disconnect the 10mm armoflex pipes and ensure there are no blockages.

# Fault Codes

## 9.0 Boiler lockouts and fault codes

In the event of a failure, the boiler will go into a lockout phase. The cause of the lockout could be down to a number of things but an error code will be displayed on the boiler panel LCD screen. **FIG 65**

This error code can be looked up below to provide possible causes of the fault.

"To Reset" the burner, you can press the reset button located under the LCD screen **FIG 65**. Alternatively, the boiler can be reset from the engineers hand held TSI when connected to the boiler.

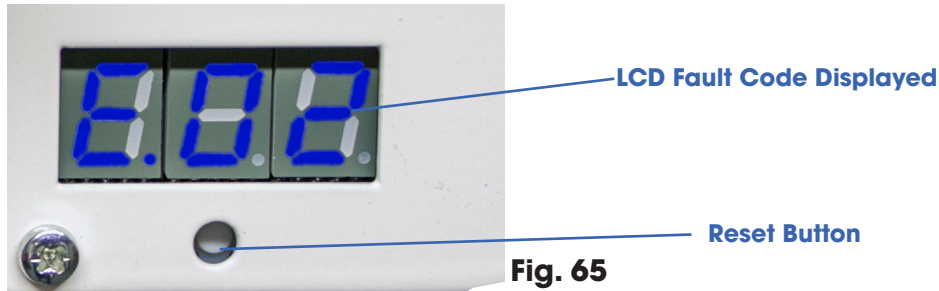

**Fig. 65**

Fault Code List		
Error Code	Description of Fault	Possible Causes
E01	Oil Pump Start-Up Failure	Check connections between control unit and pump
E02	No Flame Detected	No Fuel (faulty pump/solenoid), Faulty or Obstructed Flame Scanner (Check sight glass is clean) Faulty ignition equipment, Incorrect combustion settings
E03	Low Air Pressure	Check air pipe connection to air pressure switch and fan Faulty Air Pressure Switch or loose connection Faulty Fan Motor or loose connection
E04	Oil Pump Drive Fault	Check connections between oil pump and PCB
E05	Oil Pump Over-current	Check pump for possible seizure or lack of fuel
E06	Oil Pump Fault	Check fuel supply to pump and electrical connections
E07	Oil Pump Fault	Check fuel supply to pump and electrical connections
E08	Flame on Start Up	Faulty Flame Scanner, Check Fuel Solenoid coil is no faulty, Contamination in fuel supply Light in combustion chamber
E09	Boiler Overheat	Allow boiler to cool then reset thermostat Check external circulating water pumps Ensure sufficient flow/return to boiler.
E10	System Load Failure	Recycle power and check all values are loaded correctly via TSI.
E11	Flame After Shut-down	Check Flame Scanner Check Fuel Solenoid coil is not faulty, Contamination in fuel supply
E12	Pump Communication Failure	Check electrics and recycle power to the system
E13	Safety Communication Failure	Check electrics and recycle power to the system
E14	Incorrect Pump Pressure	Check connections between PCB and pump
E15	Incorrect Fan Speed	Check connections between PCB and Fan Maybe TSI
E16	Pump Pressure Sensor Failure	Check connections between PCB and pump
E17	Safety Reset Failure	Check electrics and recycle power to the system





Reliable energy. Flexible approach.

EOGB Energy Products Ltd, 5 Howard Road, Eaton Socon, St Neots, Cambridgeshire PE19 8ET

Tel: 01480 477066 Fax: 01480 477022 Email: [sales@sapphireboilers.co.uk](mailto:sales@sapphireboilers.co.uk)  
[www.sapphireboilers.co.uk](http://www.sapphireboilers.co.uk)



[www.youtube.com/EOGBenergyproducts](http://www.youtube.com/EOGBenergyproducts)



@EOGBburners